

not yet succeeded in unequivocally producing this anion in our system.

The bicarbonate anion was produced by the addition reaction of OH^- with CO_2 . Downstream addition of D_2O converted the HCO_3^- ion to its deuterated form. For this experiment, it was essential to form the anion in the absence of H_2CO_3 since heterogeneous exchange with D_2O might be proposed as a complicating factor.

It is interesting to compare the D_2O reactions for the anions $^- \text{CH}_2\text{NO}_2$, $^- \text{CH}_2\text{COOCH}_3$, and $^- \text{CH}_2\text{CN}$ which have been generated by proton abstraction from a methyl group. The anion from nitromethane exhibits no exchange, only clustering with D_2O . For the anion of methyl acetate exchange and clustering appear as competitive reactions while for the anion of acetonitrile, exchange reactions dominate. This trend from cluster to exchange reactions reflects the increasing basicity of the anions or, correspondingly, the decreasing acidity of their parent neutrals.

The phenomenon of hydrogen-deuterium exchange promises to have as important applications in the gas phase as in solution. It serves as a probe of the acidity of anions and frequently assists in assigning ion structures or in distinguishing between ions of the same mass. The mechanistic questions are intriguing and their full resolution would make fundamental contributions to our understanding of ion-neutral encounters.

Acknowledgments. We gratefully acknowledge support of our National Science Foundation Grant No. CHE76-11248 and the generous donation of a capacitance manometer system by MKS Instruments, Inc.

References and Notes

- (1) R. H. Shapiro, C. H. DePuy, V. M. Bierbaum, and J. H. Stewart, presented in part at the 24th Annual Conference on Mass Spectrometry and Allied Topics, San Diego, Calif., May 9–13, 1976.
- (2) B. S. Freiser, R. L. Woodin, and J. L. Beauchamp, *J. Am. Chem. Soc.*, **97**, 6893–6894 (1975).
- (3) D. P. Martinsen and S. E. Buttrill, Jr., *Org. Mass Spectrom.*, **11**, 762–772 (1976).
- (4) E. E. Ferguson, F. C. Fehsenfeld, and A. L. Schmeltekopf, *Adv. At. Mol. Phys.*, **5**, 1–56 (1969). F. C. Fehsenfeld, *Int. J. Mass Spectrom. Ion Phys.*, **16**, 151–166 (1975).
- (5) V. M. Bierbaum, C. H. DePuy, R. H. Shapiro, and J. H. Stewart, *J. Am. Chem. Soc.*, **98**, 4229–4235 (1976).
- (6) D. J. Cram, "Fundamentals of Carbanion Chemistry", Academic Press, New York, N.Y., 1965.
- (7) D. K. Bohme and L. B. Young, *J. Am. Chem. Soc.*, **92**, 3301–3309 (1970).
- (8) J. E. Bartmess, W. J. Hehre, R. T. McIver, Jr., and L. E. Overman, *J. Am. Chem. Soc.*, **99**, 1976–1977 (1977).
- (9) C. N. McEwen and F. G. Kitson, presented at the 23rd Annual Conference on Mass Spectrometry and Allied Topics, Houston, Texas, May 25–30, 1975.
- (10) In a typical experiment ~60% of the ions contained a deuterium atom, indicating that at least 60% of proton removal occurred from the methyl group. As a referee has pointed out, this represents a minimum value; hydrogen-deuterium exchange could occur in the delocalized ion-water complex resulting in deuterium loss even if initial proton abstraction occurs from the methyl group.

The Effect of Solvation on Brønsted β Values for Proton Transfer Reactions

D. J. Hupe* and Dorothy Wu

Contribution from the Department of Chemistry, University of Michigan, Ann Arbor, Michigan 48109. Received February 18, 1977

Abstract: The rates of reaction of **1** with 30 oxyanion bases in aqueous solution at 25 °C are reported. The data produce a Brønsted plot for the rate-determining enolization reaction which is definitely curved. Hydroxide ion is not anomalous but behaves like other highly basic oxyanions. Anions of hydrogen peroxide and oximes show no α effect and behave like other oxyanions of the same basicity. The cause of the curvature in the Brønsted plot is considered. A Hammond postulate argument consistent with a considerable change in transition state structure with changing catalyst $\text{p}K_a$ is contrasted with an argument based on the effects of transition state solvation. These arguments are expressed in terms of the Marcus proton transfer theory and the solvation argument is favored. Literature data are compared with that for **1**, and it is shown that two effects determine the slope of a Brønsted plot for proton abstraction from carbon. A gradual change in slope, reflecting changes in transition state bond order, is observable only over a very large change in $\Delta\text{p}K_a$ and cannot be perceived with the single substrate and homologous set of catalysts typically found in a Brønsted plot. We conclude that perturbation due to solvation of the bases involved is responsible for Brønsted plot curvature. This effect is a function only of the catalyst $\text{p}K_a$, is independent of the substrate used, and causes an increase in β for low $\text{p}K_a$ catalysts and a decrease in β for high $\text{p}K_a$ catalysts. Mechanistic ramifications of this proposed explanation are discussed.

Brønsted plots for proton transfer from carbon have been interpreted in two distinct ways. One may pass a straight line through a series of points for bases such as amines or acetates with the result that hydroxide ion falls anomalously below the line.^{1,2} This straight line implies little change in transition state structure with the change in catalyst basicity. Alternatively, one may draw a curved line through the data points (including hydroxide ion) which implies a rapid change in transition state structure with changing catalyst basicity.^{3,4} In this study, we present the rates obtained for the enolization of substrate **1** which includes data on a wide variety of oxyanions such as highly basic alkoxides, phenoxides, and oxime anions. The

Scheme I

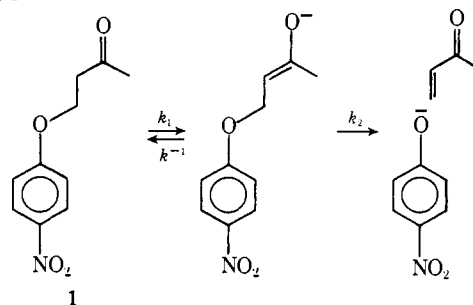

Table I. Second-Order Rate Constants for the Reaction of Phenoxides with **1** in Aqueous Solution at 25 °C and $\mu = 1.0^a$

Catalysts	pK_a^b	$k_b, M^{-1} s^{-1}$	Concn $\times 10^2, M$	pH
<i>p</i> -CH ₃ C ₆ H ₄ OH	10.07	1.38×10^{-1}	0.671–3.35	9.80
<i>p</i> -CH ₃ OC ₆ H ₄ OH	10.06	3.08×10^{-1}	0.244–2.44	9.24
C ₆ H ₄ OH	9.86	1.30×10^{-1}	1.24–6.18	9.90
		1.25×10^{-1}	0.646–3.23	9.85
C ₆ H ₄ OH (+0.322 M 4-pyridinealoxime)	9.86	1.25×10^{-1}	0.646–3.23	9.86
<i>p</i> -AcNHC ₆ H ₄ OH	9.49	7.26×10^{-2}	0.496–2.48	9.62
<i>m</i> -AcNHC ₆ H ₄ OH	9.38	6.55×10^{-2}	0.386–1.93	9.53
<i>p</i> -ClC ₆ H ₄ OH	9.28	5.05×10^{-2}	0.254–2.54	9.42
3,4-Cl ₂ C ₆ H ₃ OH	8.51	1.70×10^{-2}	0.489–2.44	8.63
3,5-Cl ₂ C ₆ H ₃ OH	7.92	9.80×10^{-3}	0.487–2.44	8.38
		9.18×10^{-3}	0.505–2.52	9.26
3,4,5-Cl ₃ C ₆ H ₂ OH	7.68	8.10×10^{-3}	0.520–2.60	8.58
F ₅ C ₆ OH	5.49	1.26×10^{-4}	0.449–2.25	7.12

^a Eight runs were done to determine each rate constant. ^b pK_a values were taken from ref 1.

Table II. Second-Order Rate Constants for the Reaction of Oxyanions with **1** in Aqueous Solution at 25 °C and $\mu = 1.0^a$

Catalysts	pK_a	$k_b, M^{-1} s^{-1}$	Concn, M	pH	R
HOH (HO ⁻)	15.75	8.33	^b		
CH ₃ CH ₂ OH	16.0 ^c	5×10	0.187–0.938	12.23	0.07
		$<8 \times 10$	0.171–0.859	10.92	
CH ₃ OH	15.7 ^c	2.5×10	0.127–1.27	12.27	0.08
		$<5 \times 10$	0.139–1.39	11.08	
CH ₂ =CHCH ₂ OH	15.5 ^c	2.5×10	0.092–0.459	10.51	0.05
		$<5 \times 10$	0.078–0.394	11.90	
HOCH ₂ CH ₂ OH	15.10 ^c	2×10	0.171–0.858	11.65	0.21
		$<3 \times 10$	0.163–0.815	11.17	
CH ₃ OCH ₂ CH ₂ OH	14.8 ^c	2.5×10	0.195–0.977	12.15	0.35
		2.2×10	0.026–0.260	11.56	0.12
		1.5×10	0.082–0.408	11.90	0.06
HC≡CCH ₂ OH	13.55 ^c	7.80	0.139–1.39	11.41	4.3
		7.48	0.127–1.27	10.67	4.7
(CH ₃) ₂ C=NOH	12.4 ^d	2.86	0.00154–0.0307	10.02	0.45
CF ₃ CH ₂ OH	12.37 ^c	3.12	0.0259–0.259	11.30	3.4
HOOH	11.60 ^e	2.05	0.0427–0.214	10.65	12
Benzaloxime	10.61 ^f	1.02	0.00517–0.0258	10.45	9.3
3-Pyridinealoxime	10.53 ^f	2.86×10^{-1}	0.00461–0.0230	10.00	2.1
<i>p</i> -Chlorobenzaloxime	10.48 ^f	7.5×10^{-1}	0.00104–0.00519	10.78	0.54
4-Pyridinealoxime	9.84 ^f	1.06×10^{-1}	0.00447–0.0223	9.95	2.3
		1.07×10^{-1}	0.00442–0.0211	9.92	2.3
Acetohydroxamic acid	9.36 ^f	1.61×10^{-1}	0.00517–0.0258	9.44	9
1,1,1,3,3,3-Hexafluoro-2-propanol	9.3 ^g	8.23×10^{-2}	0.00480–0.0242	9.48	5
3-Pyridinealoxime methiodide	9.30 ^f	5.33×10^{-2}	0.00082–0.00408	9.25	0.68
4-Pyridinealoxime methiodide	8.67 ^f	4.22×10^{-2}	0.00054–0.00273	8.50	1.5
Hexafluoroacetone hydrate	6.58 ^g	5.63×10^{-4}	0.0054–0.0270	6.69	12
CH ₃ COOH	4.76 ^e	1.18×10^{-5}	0.050–0.251	6.74	6

^a Between 8 and 12 runs were done to determine each rate constant. ^b This value was determined from the average of 13 k_{obsd} values obtained by extrapolation of the phenoxide data to zero catalyst concentration. ^c Reference 15. ^d Reference 56. ^e Reference 16. ^f Measured in this study as described in the Experimental Section. ^g Reference 57.

catalysts chosen varied enough in pK_a so that it would be possible to determine conclusively whether curvature occurs.

Experimental Section

Compound **1** was synthesized by reaction of *p*-nitrophenol with methyl vinyl ketone. In a typical synthesis, 25 g (0.18 mol) of *p*-nitrophenol was added to 50 g (0.71 mol) of methyl vinyl ketone and the mixture was stirred at 45 °C after adding 0.05 g of *p*-toluenesulfonic acid. The reaction was followed by observing the appearance of the triplets at δ 2.9 and 4.3 in ¹H NMR spectra of the reaction mixture. A maximum concentration of product was achieved after about 6 h. Decomposition occurs with longer reaction times. The reaction mixture was diluted with 75 mL of chloroform and cooled in order to precipitate a large amount of unreacted *p*-nitrophenol. The remaining solution was diluted with 200 mL of ether and extracted with a 100-mL portion of 0.1 N HCO₃⁻ buffer to remove the *p*-toluenesulfonic acid. Removal of solvent and unreacted methyl vinyl ketone under reduced pressure left a brown oil still containing a large amount of *p*-nitrophenol. This material was extracted ten times from ether

with 100-mL portions of CO₃²⁻ buffer. The ether layer was dried over Na₂SO₄ and the solvent removed to form crude **1**. Recrystallization from ether yielded 7.5 g (0.36 mol, 20%) of colorless, crystalline **1**: mp 66–67 °C; NMR (CDCl₃) δ 2.2 (3 H, s), 2.9 (2 H, t), 4.3 (2 H, t), 6.9 (2 H, d), 8.2 (2 H, d); IR (KBr) 1720 cm⁻¹. Anal. Calcd: C, 57.40; H, 5.30; N, 6.69. Found: C, 57.49; H, 5.42; N, 6.63.

The substituted oximes used in this study were prepared by known methods⁵ and were recrystallized before use. Melting points and NMR data were consistent with each being pure *E* isomer.⁶ All alcohols were distilled several times before use and phenols were purified by recrystallization or by sublimation. Solutions of H₂O₂ were standardized by iodometric titration and a control experiment showed that H₂O₂ was not destroying O₂NC₆H₄O⁻ as it was formed.

The pK_a values for a number of the catalysts were determined under conditions identical with those used in the kinetic studies (25°, $\mu = 1.0$). These were measured spectrophotometrically by diluting aliquots of the compound with carbonate buffer at various pH values and observing the absorbance due to the anion. The value of K_a was determined from the slope of plots of [B]/[BH⁺] vs. 1/[H⁺] defined by at least ten points. The results of these measurements are included in Tables I and II.

The rates of reaction of **1** with various catalysts were obtained by measuring the production of yellow *p*-nitrophenoxide at 400 nm using a McPherson automated spectrophotometer thermostated at 25 °C. Typically, four runs were done simultaneously and the reactions were routinely followed to 10 half-lives. The ionic strength was maintained at 1.0 by addition of KCl. Serial dilutions of catalyst were done so as to maintain constant pH and μ . In all cases, the rate constant obtained was independent of the concentration of substrate used. The concentrations of catalyst were usually at least 100 times greater than the concentration of substrate.

The pH control during the reaction was usually maintained by having the catalyst act as the buffer for the reactions. For the reactions of alkoxides, however, in order to avoid the complications arising from an additional buffer, the reactions were run in unbuffered solution and pH control was maintained by rigorous exclusion of carbon dioxide. The stock solutions of reactants were carefully adjusted to the same pH with small amounts of sodium hydroxide solution and the pH values of the reaction mixture were taken immediately after the run. All stock and reactant solutions were kept under argon.

In a typical experiment, a weighed amount of phenol or alcohol was dissolved in doubly distilled, freshly boiled water and cooled under an argon atmosphere, and enough KCl was added to give $\mu = 2.0$ M. The pH of this solution was then adjusted to the desired value and a similarly prepared 2.0 M KCl solution was adjusted to an identical pH. After bringing these solutions to the proper volume, they were mixed in varying ratios. The reactions were initiated by mixing these solutions with an equivalent volume of a dilute solution of **1** to give the reaction mixture. Typically, between 8 and 12 runs at a given pH value with a series of catalyst concentrations were done.

The reactions were usually followed for 10 half-lives and the values of k_{obsd} were determined from the least-squares slope of $\ln(1 - A/A_\infty)$ vs. time with a correlation coefficient typically ≥ 0.99 . These values of k_{obsd} were plotted vs. the concentration of alkoxide or phenoxide in order to obtain the values of k_b listed in Tables I and II. The value of k_b for OH^- was obtained by extrapolation to zero catalyst concentration for a number of catalysts. By plotting these intercepts vs. OH^- concentration, the rate constant for this catalyst was determined. No water-catalyzed rate was observed.

Results

The reaction of **1** with bases in aqueous solution followed the rate law $v = k_{\text{OH}}[\text{OH}^-][\text{1}] + k_b[\text{B}][\text{1}]$, where the rate constants are those listed in Tables I and II. The values of k_{obsd} obtained for a given set of catalytic conditions were independent of the concentration of **1**. The plots of k_{obsd} vs. $[\text{RO}^-]$ showed the same slope at various pH values indicating dependence only on the basic form of the buffer.

A control experiment was done in which the rate constant for the phenoxide catalyzed reaction was determined in the presence and absence of 0.322 M 4-pyridinealoxime. Identical rate constants were obtained for phenoxide ion in both cases. Another control experiment was performed in which the rate constant due to 0.261 M trifluoroethanol was measured at pH 11.1 while varying the concentration of ethanol present. Eight concentrations of ethanol were used between 0 and 0.4 M and no effect on the rate due to hydroxide and trifluoroethoxide was observed.

For most catalysts of $\text{p}K_a = 13.55$ and below the contribution of the catalyst to the observed rate was large under the experimental conditions chosen. For example, in Figure 1 is shown a plot of k_{obsd} vs. the concentration of the anion of propargyl alcohol in which the ratio of alkoxide to hydroxide ion rates, R , is 4.7 at the highest catalyst concentration. For lower $\text{p}K_a$ catalysts, this ratio is greater since the basic form of the catalyst can exist in high concentration even when the hydroxide ion concentration is low. For higher $\text{p}K_a$ catalysts, however, it is more difficult to measure the rate constants because of the greater competition of unavoidable hydroxide ion catalysis. These measurements were made even more difficult because the unbuffered solutions used were subject to pH variation if CO_2 absorption was not prevented. As shown in Figure 1, a much smaller contribution to the overall rate is

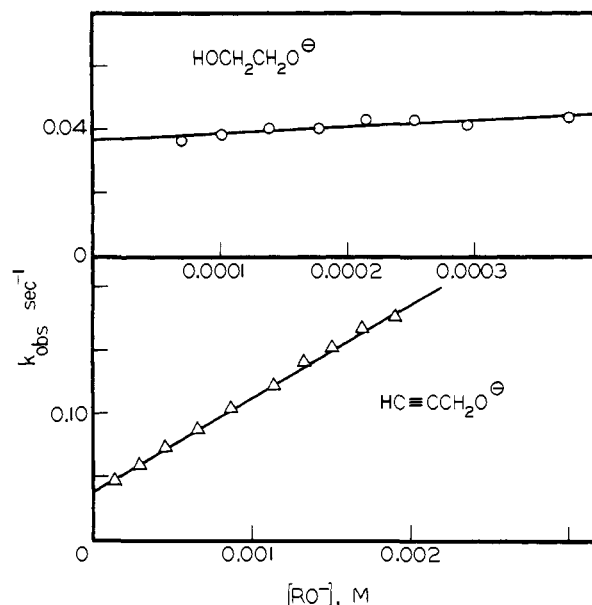

Figure 1. Plots of k_{obsd} values vs. catalyst concentration for two alkoxides, demonstrating the cases where the catalyst's contribution to the overall rate is small or large. The data for $\text{HOCH}_2\text{CH}_2\text{O}^-$ were obtained at pH 11.65 and have a least-squares slope, $k_b = 2.2 \times 10^1 \text{ M}^{-1} \text{ s}^{-1}$ (correlation coefficient 0.853). The ratio of catalyst rate to hydroxide rate at highest catalyst concentration is $R = 0.21$. The data for $\text{HC}\equiv\text{CCH}_2\text{O}^-$ have a slope $k_b = 7.48 \text{ M}^{-1} \text{ s}^{-1}$ (correlation coefficient 0.999) and $R = 4.7$.

obtained with the higher $\text{p}K_a$ alcohol ethylene glycol ($R = 0.16$), even though the total alcohol concentration was approximately 1 M. The values of R shown in Table II indicate that the rate constants for the three most basic alkoxides are approximate. It is quite certain, however, that the values of the rate constants for these catalysts are not larger than those listed in Table II and plotted in Figure 2.

The Brønsted plot of $\log k_b$ vs. $\text{p}K_a$ is shown in Figure 2. The solid line passing through the points was computed using the Marcus expression as outlined in the Discussion section. The dashed line represents the least-squares slope through the points for catalysts with a $\text{p}K_a$ less than 10.62, which has a slope of 0.75 (correlation coefficient = 0.988).

Discussion

In order for **1** to be useful as a substrate for studying enolization reactions, it is, of course, necessary to show that enolization is rate determining ($k_2 > k_{-1}$). It is also necessary, however, to show that the loss of the leaving group is not concerted with proton abstraction. If there is substantial E2 character in the transition state the structure-reactivity correlations measured would not reflect the isolated proton transfer event and therefore would not be comparable to enolization data obtained from other types of substrates.

Elimination reactions involving carbanions which are either enolate anions⁷⁻¹¹ or nitronate anions^{12,13} have been studied extensively. Only when leaving groups are very basic such as hydroxide⁷ and methoxide^{11,13} is $k_{-1} > k_2$ as shown by the incorporation of deuterium at the α position in D_2O solution at a rate faster than elimination. When better leaving groups, such as acetate,^{8,9,13} benzoates,¹⁴ and weakly basic phenoxides,¹¹ are involved, proton loss is rate determining and the leaving group is expelled rapidly in a second step ($k_2 > k_{-1}$). This was confirmed by observing no deuterium incorporation in D_2O solution⁸ and also by observing a primary isotope effect when deuterated substrates were used.^{7,8} Substrate **1** is a 4-(*p*-substituted phenoxy)-2-butanone, and the elimination mechanism of this group of compounds has been studied by

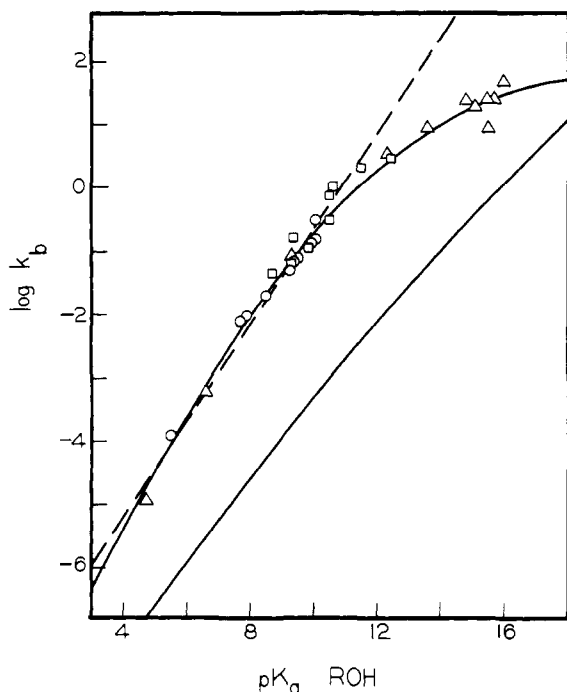

Figure 2. A plot of $\log k_b$ values from Tables I and II vs. the pK_a values of the catalysts which include phenoxides (O), alkoxides, hydroxide and acetate ions (Δ), and α -effect oxyanions (\square). The dashed line is the least-squares fit of the points for bases of $pK_a \leq 10.62$ with a slope of 0.75 (correlation coefficient 0.988). The sharply curving line fitting the data points was computed using eq 1 with $\Delta G_0^\ddagger = 2.5$ kcal, $w_r = 15.1$ kcal, and assuming a substrate pK_a of 11.1 as described in the text. A gently curving solid line ($\Delta G_0^\ddagger = 10$ kcal, substrate $pK_a = 16.5$) has been added for comparison.

Fedor.¹¹ He showed that a compound like **1**, with a weakly basic phenoxide as the leaving group, would exhibit rate-determining proton abstraction under the conditions used in this study.

In order to show that there is little E2 character and that proton transfer alone is being measured, it is necessary to show that the rate of proton abstraction is independent of the leaving group. Bordwell has shown that for elimination reactions of β -nitroacetates an irreversible second-order carbanion elimination occurs with no E2 component since the only change in the proton abstraction rate with leaving group variation is due to a small inductive effect.^{12,13} The same observation has been made^{7,8} concerning the similar proton abstraction rates of a β -hydroxy and a β -acetoxy ketone whose leaving group basicities differ by a factor of 10^{11} . Fedor's data on 4-(*p*-substituted)-2-butanones suggest the same interpretation for **1** since variation of the leaving group has little effect on the proton abstraction rate ($\rho = 0.06$).¹¹ An effect this small could be due to the inductive effect on the proton transfer reaction.¹³

We conclude, therefore, that substrate **1** will yield rate data that reflect the proton transfer alone and that the structure-reactivity correlations obtained in these studies are comparable to similar data obtained by deuterium exchange or halogenation reactions of other ketones. As shown below the absolute magnitudes of the rate constants and the Brønsted β values determined for **1** are comparable to those found for similar carbon acids.

The measurement of rate constants for enolization caused by highly basic catalysts in aqueous solution is made difficult because of the substantial competing hydroxide ion catalysis. As described in the Experimental Section the fact that **1** allows the precise spectrophotometric measurement of small changes in rate helps to solve this problem. Even for the highest pK_a alcohols which exhibit only a small slope in plots of k_{obsd} vs.

$[\text{RO}^-]$, it is certain that rate constants are not larger than those listed in Table II, which assures the curvature of the Brønsted plot in Figure 2.

The fact that high concentrations of the higher pK_a alcohols are necessary in order to observe catalysis introduces the possibility that the change in the medium could be causing a change in the rate constant for reaction of alkoxide or hydroxide ions with **1**. In order to ensure that this effect was not large, an experiment was done with 0.261 M trifluoroethanol at pH 11.1 such that 20% of the elimination of **1** was caused by hydroxide and 80% was caused by trifluoroethoxide. Addition of up to 0.4 M ethanol to these reaction mixtures (under conditions where the contribution due to ethoxide is negligible) caused no observable change in the rate of reaction of **1**. We infer from this observation that the medium effect on the measured rate constants due to the presence of substantial alcohol concentration is small.

Another problem arises with the high pK_a alcohols since their pK_a values were determined conductometrically at zero ionic strength¹⁵ and may therefore be the incorrect values to use when $\mu = 1.0$. While no physical means of directly measuring alcohol pK_a values at high ionic strength exists, there are a number of structure-reactivity correlations that have been measured at high ionic strength that rely on these same pK_a^\ddagger values for their observed linearity. These include both the rates and equilibria for the reaction of phenoxides and alkoxides with acetic acid,^{16,17} the elimination of alkoxides and phenoxides from *N*-phenylcarbamate esters,¹⁸ and the elimination of alkoxides from monoalkyl carbonates.¹⁹ In light of these linear relationships, it seems unlikely that the curvature described below could be due to erroneous pK_a values.

In addition to the phenoxides and alkoxides, a series of α -effect compounds was also used as enolization catalysts. Inspection of Figure 2 reconfirms the fact that these compounds are not extraordinarily reactive as they are in nucleophilic processes.^{20,21} In order to ensure that a greater reactivity by α -effect compounds was not being offset by complexation of **1** through hemiketal formation, the rate constant for phenoxide ion catalyzed enolization was determined with 0.322 M 4-pyridinealdoxime present. The same rate constant for phenoxide was obtained in the presence and absence of the oxime indicating that no substantial amount of complexation occurred.

The Brønsted plot shown in Figure 2 exhibits substantial curvature. The data for bases of $pK_a = 3$ –10 fall close to a straight line of slope 0.75 while those above $pK_a = 10$ fall rapidly to a slope of about 0.3. This curvature might be interpreted as a dramatic example of the Hammond postulate in which the transition state structure becomes more reactant-like for higher pK_a bases. A quantitative expression of the Hammond postulate argument for proton transfer is embodied in the Marcus formalism,^{3,4} which allows separation of the free energy of activation, ΔG^\ddagger , into the energy (including solvation energy) required to bring the reactants together, w_r , and the energy involved in the proton transfer itself, $(1 + \Delta G_0/4\Delta G_0^\ddagger)^2 \Delta G_0^\ddagger$. In this expression ΔG_0 is the free energy for the proton transfer at equilibrium and ΔG_0^\ddagger (termed the intrinsic barrier) is the free energy of activation for the proton transfer when $\Delta G_0 = 0$.

$$\Delta G^\ddagger = \left(1 + \frac{\Delta G_0}{4\Delta G_0^\ddagger}\right)^2 \Delta G_0^\ddagger + w_r \quad (1)$$

Equation 1 successfully predicts the rapid change of slope from 0 to 1 in Brønsted plots for proton transfer between electronegative atoms²² using small values of w_r ($= 4$ kcal) and ΔG_0^\ddagger ($= 2.5$ kcal) as shown in Figure 3. When a carbon acid is involved in the proton transfer reaction, generally much slower proton transfers are observed, even in the thermodynamically favored direction. There is not complete agreement

on whether this slow rate is due to a large value of w_r or a large value of ΔG_0^\ddagger , as shown in Figure 3.

The data from a number of studies of proton transfer reactions have been fit with curved lines (with a small ΔG_0^\ddagger and a large w_r) implying a large change in transition state structure with a small change in catalyst pK_a . These include data for the protonation of diazoacetate, by ammonium ions²³ and oxygen acids,²⁴ the protonation of diazo esters by carboxylic acids,^{24,25} and the enolization of acetylacetone by oxyanions.^{24,26} Some of the interpretations of these data have been questioned^{27,28} because the presence of curvature relies on passing the line through the points for hydroxide or hydronium ion. The same data might otherwise be interpreted by passing a straight line through a homologous series of bases and having hydroxide ion fall below that line. This is typical of the way in which enolization data have been presented²⁹⁻³² and the negative deviation for hydroxide ion from the straight line has been termed the "hydroxide ion anomaly".^{1,2}

If the hydroxide ion point is ignored, a much different interpretation of the data arises wherein the ΔG_0^\ddagger is much larger and w_r smaller. Consistent with this interpretation is Kemp's study of proton abstraction reactions involving a homologous series of bases which exhibit no curvature and no change in slope even when the reactivity of the carbon acid is varied considerably.^{27,28} Also consistent with this interpretation are Bell's collected data for the rates of proton transfer by a homologous series of catalysts with a variety of carbon acids showing only a very gradual change in slope.³³ A plot of $\log k$ vs. ΔpK_a for these data can be fit by a line with $\Delta G_0^\ddagger = 10$ kcal and $w_r = 4$ kcal. As shown in Figures 2 and 3, a curve of this type requires a large change in ΔpK_a in order to cause a change in slope of from 0 to 1.0 implying an equally gradual change in transition state structure with ΔpK_a . The best evidence that this gradual change in slope reflects the actual change in transition state structure is the fact that a plot of k_H/k_D values vs. ΔpK_a for a variety of carbon acids exhibits a similar gradual change.^{34,35}

Two distinct interpretations exist, therefore, for data involving proton transfer to and from carbon. The first ascribes a rapidly curving Brønsted plot to a rapidly changing transition state structure. This is consistent with a large w_r and small ΔG_0^\ddagger and relies heavily on passing the curved line through either hydroxide ion or hydronium ion. The second interpretation relies on ignoring "anomalous" hydroxide or hydronium ion or (equivalently) using homologous series of bases with a variety of carbon acids. This generates a very gradually sloping curve in which ΔG_0^\ddagger is large and w_r is small and indicates a very gradually changing transition state structure.

It is clear from Figure 2 that it is appropriate to draw a line that is sharply curved through the data points. Hydroxide ion is not "anomalous" but fits well with other oxygen bases of high pK_a . The solid line in Figure 2 was computed using eq 1 with $\Delta G_0^\ddagger = 2.5$ kcal and $w_r = 15.1$ kcal. Figure 2 shows a slope of about 0.5 at $pK_a = 11.1$ and this should correspond to the point where $\Delta G_0 = 0$ in the Marcus expression. In order to obtain a good fit with the data, therefore, a pK_a of 11.1 had to be used for substrate 1, which is much different than the value of approximately 16.5 expected based on the pK_a of cyclohexanone.³⁶

An assignment of $\Delta G_0^\ddagger = 2.5$ kcal and $w_r = 15.1$ kcal implies a very rapid change in the degree of proton transfer in the transition state with a change in catalyst pK_a . The change from $\beta = 0.8$ at $pK_a = 6$ to $\beta = 0.2$ at $pK_a = 16$ implies a dramatic change from late to early transition state with a relatively small change of 10 pK_a units. The major barrier to proton transfer is the large work term reflecting the energy required to bring the reactants together.

This interpretation of the data in Figure 2 is not satisfying for several reasons. The fact that the slope is not 0.5 at ΔpK_a

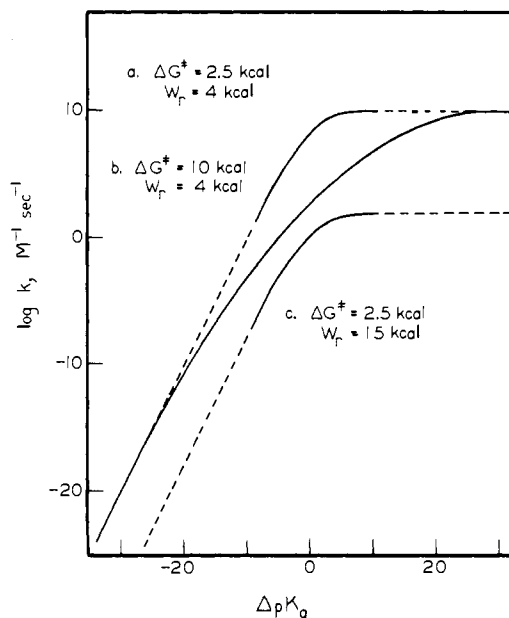

Figure 3. The curves shown were generated by eq 1 using the following values, in kcal, of ΔG_0^\ddagger and w_r , respectively: a, 2.5, 4.0; b, 10, 4.0; c, 2.5, 15. Curve a is the type found for proton transfer between electronegative atoms. Curves b and c represent the two types of interpretations that exist for proton transfer involving carbon, as discussed in the text.

= 0 is not readily explained. There is also no apparent reason why w_r should be so large for enolization and yet very small for a reaction such as the deprotonation of phenylacetylene.³⁷ It would seem more reasonable that the slower rate for enolization is due to a larger intrinsic barrier arising from the requisite changes³⁸ in C-O and C-C bond length during the reaction. For comparison, a line computed with eq 1 using $\Delta G_0^\ddagger = 10$ kcal has been added to Figure 2, assuming the substrate pK_a to be 16.5. This shows the degree of curvature expected if Bell's data³³ accurately reflect the change in transition state structure.

In Figure 4 is shown the same data set that was presented in Figure 3, along with similar sets for acetone^{39,40} ($pK_a = 20$), acetylacetone²⁶ ($pK_a = 8.0$), and ethyl nitroacetate⁴¹ ($pK_a = 5.8$). While each sharply curving line has been calculated with the same ΔG_0^\ddagger of 2.5 kcal, various values of w_r have been used. The data in Figure 4 suggest that the measured β values for proton transfer from carbon might arise from a combination of two effects. One effect is the gradual change in slope due to change in transition state structure and consistent with $\Delta G_0^\ddagger = 10$ kcal. The change in slope due to this effect is virtually invisible with any homologous set of catalysts and a single substrate. The second effect which influences the measured value of β is one which is independent of the substrate and is a function only of the catalyst pK_a . As shown in Figures 4 and 5, the difference between the observed rates for a proton transfer reaction and that expected for one with $\Delta G_0^\ddagger = 10$ is a bell-shaped curve. These bell-shaped curves do not overlap when plotted vs. ΔpK_a but are similar when plotted vs. catalyst pK_a . A combination of these two effects may be responsible for the dramatically different pictures of the proton transfer reaction obtained depending upon the type of data used.

Whereas the changing position of the proton in the transition state is responsible for the gradual change in slope, an explanation is needed for the independent perturbing effect which causes any given set of catalysts to define a sharply curved Brønsted plot like that in Figure 2. In terms of the Marcus equation, since $\Delta G_0^\ddagger = 10$ kcal, the curvature must be caused by a changing value of w_r . While Marcus allowed for this possibility,^{3,4} it has been tacitly assumed that w_r is a constant

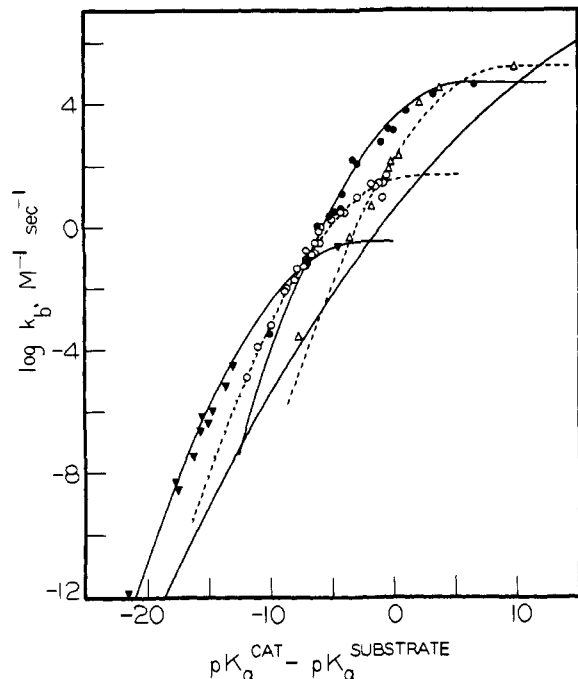

Figure 4. A series of Brønsted plots is shown for four carbon acids including ethyl nitroacetate, $pK_a = 5.8$ (Δ); acetoacetate, $pK_a = 8.0$ (\bullet); substrate 1, $pK_a = 16.5$ (\circ); and acetone, $pK_a = 20$ (\blacktriangledown). Each is fitted with a curved line calculated with eq 1 using $\Delta G_0^\ddagger = 2.5$ kcal. For comparison the gently sloping solid line was added for which $\Delta G_0^\ddagger = 10$ kcal.

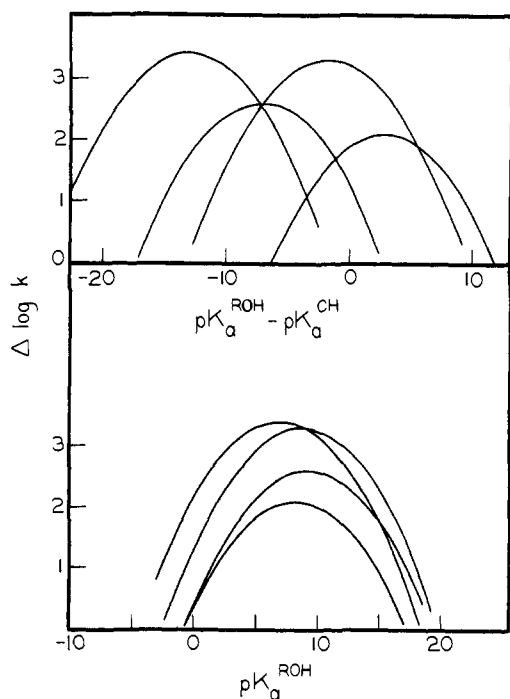

Figure 5. A set of curves generated by subtracting the $\Delta G_0^\ddagger = 10$ kcal curve from the others presented in Figure 4. These curves do not coincide when they are plotted vs. ΔpK_a but appear to be similar when plotted vs. the catalyst pK_a . The perturbation giving rise to Brønsted plot curvature appears to be dependent only on catalyst pK_a and is independent of substrate pK_a .

in most proton transfer studies. It is known that the solvation energy of oxyanions increases greatly with increasing basicity,^{42,43} and it is reasonable therefore to expect w_r to reflect this change.

It would be reasonable to ascribe an increase in β to solvation since the effective negative charge on the attacking base would

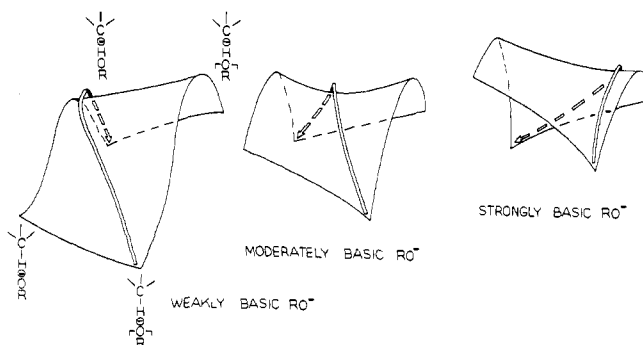
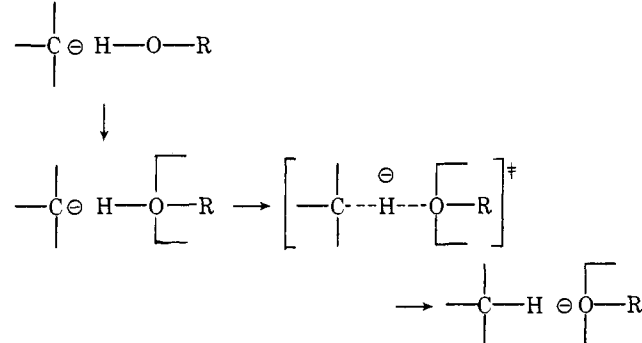

Figure 6. Three-dimensional energy surfaces showing the proposed change in the solvation energy of transition states as a function of catalyst basicity. The upper right-hand corner is higher in energy than the product because of the unfavorable position of the solvent molecules around ROH. The lower left-hand corner is higher in energy than the reactants because of the large stabilizing effect of solvent on oxyanions. This effect is more important for more basic anions.

be diminished by accompanying solvent molecules.¹⁷ There is considerable evidence that suggests that the proton transfer event occurs much more rapidly than does the relaxation of the surrounding solvent molecules.⁴⁴⁻⁴⁸ The solvation shell of the oxyanion may therefore be left in position during the transition state. The reverse reaction would then require the energetically unfavorable formation of a solvation shell prior to charge development as shown in Scheme II. The stabilization achieved

Scheme II



by solvation of the partial negative charge on oxygen would tend to be offset because of the unfavorable position in which the solvent molecules are left. These two opposing forces may possibly be responsible for the bell-shaped perturbation on β shown in Figure 5.

It has recently become popular to use three-dimensional diagrams to make mechanistic arguments more easily visualized.^{49,50} In Figure 6 is shown a family of such diagrams in which solvated and desolvated pathways for proton transfer are separated. The position of the transition state is determined by the energy of desolvation of the oxyanion and by the energy required to solvate ROH. Energy surfaces such as these would produce a curved Brønsted plot.

If this picture is correct, then the typical Brønsted plot for a series of bases defining a straight line (with hydroxide ion falling below the line) would require the following interpretation. The value of β would be greater than the bond order for O-H bond formation in the transition state because of the enhancement of β due to solvation for the lower pK_a bases. The "anomalously" low rate for hydroxide (which actually is comparable to other bases of the same pK_a) exists because the stabilizing effect of solvation is offset as the solvating molecules are left in an unfavorable position. The slow rate of proton loss from carbon acids relative to oxygen or nitrogen acids arises from the large value of ΔG_0^\ddagger caused by the need for heavy

atom reorganization. This interpretation is consistent with the fact that ΔS^\ddagger for proton transfer from carbon to hydroxide ion is a much more negative value than the corresponding value for phenoxide.^{51,52} The fact that no hydroxide ion anomaly (equivalent to curvature) has been found for proton transfers between electronegative atoms^{1,2} might reflect the fact that these reactions occur through solvent molecules^{53,54} whereas those involving carbon do not,⁵⁵ as suggested by Kresge.¹

References and Notes

- (1) A. J. Kresge, *Chem. Soc. Rev.*, **2**, 475 (1973).
- (2) A. J. Kresge, *Acc. Chem. Res.*, **8**, 354 (1975).
- (3) R. A. Marcus, *J. Phys. Chem.*, **72**, 891 (1968).
- (4) A. O. Cohen and R. A. Marcus, *J. Phys. Chem.*, **72**, 4249 (1968).
- (5) A. Raoult and M. Vilkas, *Bull. Soc. Chim. Fr.*, 3316 (1968).
- (6) E. Pozioemek, D. Kramer, W. Mosher, and H. Michael, *J. Am. Chem. Soc.*, **83**, 3916 (1961).
- (7) D. J. Hupe, M. C. R. Kendall, G. T. Sinner, and T. A. Spencer, *J. Am. Chem. Soc.*, **95**, 2260 (1973).
- (8) D. J. Hupe, M. C. R. Kendall, and T. A. Spencer, *J. Am. Chem. Soc.*, **94**, 1254 (1972).
- (9) L. R. Fedor, *J. Am. Chem. Soc.*, **89**, 4479 (1967).
- (10) L. R. Fedor, *J. Am. Chem. Soc.*, **91**, 909 (1969).
- (11) L. R. Fedor and W. R. Glave, *J. Am. Chem. Soc.*, **93**, 985 (1971).
- (12) F. G. Bordwell, K. C. Yee, and A. C. Knipe, *J. Am. Chem. Soc.*, **92**, 5945 (1970).
- (13) F. G. Bordwell, M. M. Vestling, and K. C. Yee, *J. Am. Chem. Soc.*, **92**, 5950 (1970).
- (14) R. C. Cavestri and L. R. Fedor, *J. Am. Chem. Soc.*, **92**, 4610 (1970).
- (15) P. Ballinger and F. A. Long, *J. Am. Chem. Soc.*, **82**, 795 (1960).
- (16) A. R. Ferscht and W. P. Jencks, *J. Am. Chem. Soc.*, **92**, 5442 (1970).
- (17) D. J. Hupe and W. P. Jencks, *J. Am. Chem. Soc.*, **99**, 451 (1977).
- (18) A. Williams, *J. Chem. Soc., Perkin Trans 2*, 1244 (1973).
- (19) C. K. Sauers, W. P. Jencks, and S. Groh, *J. Am. Chem. Soc.*, **97**, 5546 (1975).
- (20) R. F. Pratt and T. C. Bruice, *J. Org. Chem.*, **37**, 3563 (1972).
- (21) W. P. Jencks, "Catalysis in Chemistry and Enzymology", McGraw-Hill, New York, N.Y., 1969, p 107.
- (22) M. Eigen, *Angew. Chem., Int. Ed. Engl.*, **3**, 1 (1964).
- (23) M. M. Kreevoy and D. E. Konasewich, *Adv. Chem. Phys.*, **21**, 241 (1971).
- (24) M. M. Kreevoy and S.-W. Oh, *J. Am. Chem. Soc.*, **95**, 4805 (1973).
- (25) W. J. Albery, A. N. Campbell-Crawford, and J. S. Curran, *J. Chem. Soc., Perkin Trans. 2*, 2206 (1972).
- (26) Von M.-L. Ahrens, M. Eigen, W. Kruse, and G. Maass, *Ber. Bunsenges. Phys. Chem.*, **74**, 380 (1970).
- (27) D. S. Kemp and M. Casey, *J. Am. Chem. Soc.*, **95**, 6670 (1973).
- (28) M. Casey, D. S. Kemp, K. Paul, and D. Cox, *J. Org. Chem.*, **38**, 2294 (1973).
- (29) J. Hine, J. G. Houston, J. H. Jensen, and J. Mulders, *J. Am. Chem. Soc.*, **87**, 5050 (1965).
- (30) R. P. Bell, R. D. Smith, and L. A. Woodward, *Proc. R. Soc. London, Ser. A*, **192**, 479 (1948).
- (31) R. P. Bell, E. Gelles, and E. Möller, *Proc. R. Soc. London, Ser. A*, **198**, 310 (1949).
- (32) R. P. Bell and H. L. Goldsmith, *Proc. R. Soc. London, Ser. A*, **210**, 322 (1952).
- (33) R. P. Bell, "The Proton in Chemistry", 2nd ed, Cornell University Press, Ithaca, N.Y., 1973, p 203.
- (34) R. P. Bell and D. M. Goodall, *Proc. R. Soc. London, Ser. A*, **294**, 273 (1966).
- (35) F. G. Bordwell and W. J. Boyle, Jr., *J. Am. Chem. Soc.*, **93**, 512 (1971).
- (36) R. P. Bell and P. W. Smith, *J. Chem. Soc. B*, 241 (1966).
- (37) A. J. Kresge and A. C. Lin, *J. Chem. Soc., Chem. Commun.*, 761 (1973).
- (38) F. Hibbert and F. A. Long, *J. Am. Chem. Soc.*, **94**, 2647 (1972).
- (39) R. P. Bell and O. M. Lidwell, *Proc. R. Soc. London, Ser. A*, **176**, 88 (1940).
- (40) M. Bender and A. Williams, *J. Am. Chem. Soc.*, **88**, 2502 (1966).
- (41) D. J. Barnes and R. P. Bell, *Proc. R. Soc. London, Ser. A*, **318**, 421 (1970).
- (42) L. A. Cohen and W. M. Jones, *J. Am. Chem. Soc.*, **85**, 3397 (1963).
- (43) E. M. Arnett, L. E. Small, R. T. McIver, Jr., and J. S. Miller, *J. Am. Chem. Soc.*, **96**, 5638 (1974).
- (44) R. P. Bell, *Discuss. Faraday Soc.*, **39**, 16 (1965).
- (45) E. Grunwald and E. Price, *J. Am. Chem. Soc.*, **86**, 2970 (1964).
- (46) E. Grunwald, *Prog. Phys. Org. Chem.*, **3**, 317 (1965).
- (47) M. M. Kreevoy and R. Kretschmer, *J. Am. Chem. Soc.*, **86**, 2435 (1964).
- (48) J. L. Kurz and L. C. Kurz, *J. Am. Chem. Soc.*, **94**, 4431 (1972).
- (49) R. A. More O'Ferrall, *J. Chem. Soc. B*, 274 (1970).
- (50) W. P. Jencks, *Chem. Rev.*, **72**, 705 (1972).
- (51) Z. Margolin and F. A. Long, *J. Am. Chem. Soc.*, **95**, 2757 (1973).
- (52) E. A. Walters and F. A. Long, *J. Am. Chem. Soc.*, **91**, 3733 (1969).
- (53) R. A. More O'Ferrall in "Proton Transfer Reactions", E. F. Caldin and V. Gold, Ed., Wiley, New York, N.Y., 1975, pp 103, 289.
- (54) W. J. Albery, *Prog. React. Kinet.*, **4**, 353 (1967).
- (55) D. M. Goodall and F. A. Long, *J. Am. Chem. Soc.*, **90**, 238 (1968).
- (56) W. P. Jencks and J. Carriuolo, *J. Am. Chem. Soc.*, **82**, 1778 (1960).
- (57) D. Yarkin, E. Mochalina, and I. Knunyants, *Tetrahedron*, **21**, 2991 (1965).

The Effect of Solvation on β Values for Nucleophilic Reactions

D. J. Hupe,* Dorothy Wu, and Paul Shepperd

Contribution from the Department of Chemistry, University of Michigan, Ann Arbor, Michigan 48109. Received February 18, 1977

Abstract: The rates of enolization of **1** catalyzed by a series of oxyanions are compared with the reactions of esters in which the oxyanions function as nucleophiles involved in rate-determining attack. The similarity in curvature of these two plots is demonstrated. The cause of the curvature for nucleophilic reactions of PNPA and PNTPA is suggested to arise from a perturbation due to solvation similar to that proposed for **1**. The value of β_{nuc} for phenoxides is enhanced because of the solvation shell accompanying the oxyanion in the transition state. A countervailing force arises because of the unfavorable position in which solvent molecules are left which results in the lower value of β for high pK_a oxyanions. This proposed explanation is consistent with two other experimental facts. The curvature due to the solvation perturbation disappears when the reaction involves rate-determining breakdown of the tetrahedral intermediate, as expected if enough time exists for relaxation of solvent molecules to occur. The reactions of the same oxyanions with the pivalate esters PNPP and PNTPP show a lower β_{nuc} value for phenoxides and smaller negative deviations for alkoxides as expected if these more hydrophobic and sterically hindered substrates were to inhibit transition state solvation.

In the previous paper, evidence was presented to show that Brønsted plots for proton transfer from carbon were sharply curved.¹ This curvature was suggested to be caused by a solvation effect rather than by a "Hammond postulate" type of change in transition state structure. An essential feature of the solvation argument was the requirement that proton transfer occurred more rapidly than solvent reorganization. This in-

creased the rates of reaction (and β for low pK_a bases) by stabilizing the partial negative charge on oxygen in the transition state. An offsetting force arose for high pK_a bases because of the energetically unfavorable position in which solvating molecules were left, resulting in the observed curvature.

The same type of argument might be made for reactions in